

AEGEX 3D

Building permanent homes in 24–48 hours through mobile 3D printing for disaster recovery and affordable housing.

Ujagar Pratap Singh, Zizheng Li, Kyle Pearson



JOHNS HOPKINS
WHITING SCHOOL
of ENGINEERING

1. PROBLEM STATEMENT

In the U.S., post-disaster permanent rebuilding takes **2 - 5 YEARS**, trapping up to **480,000** families in limbo.

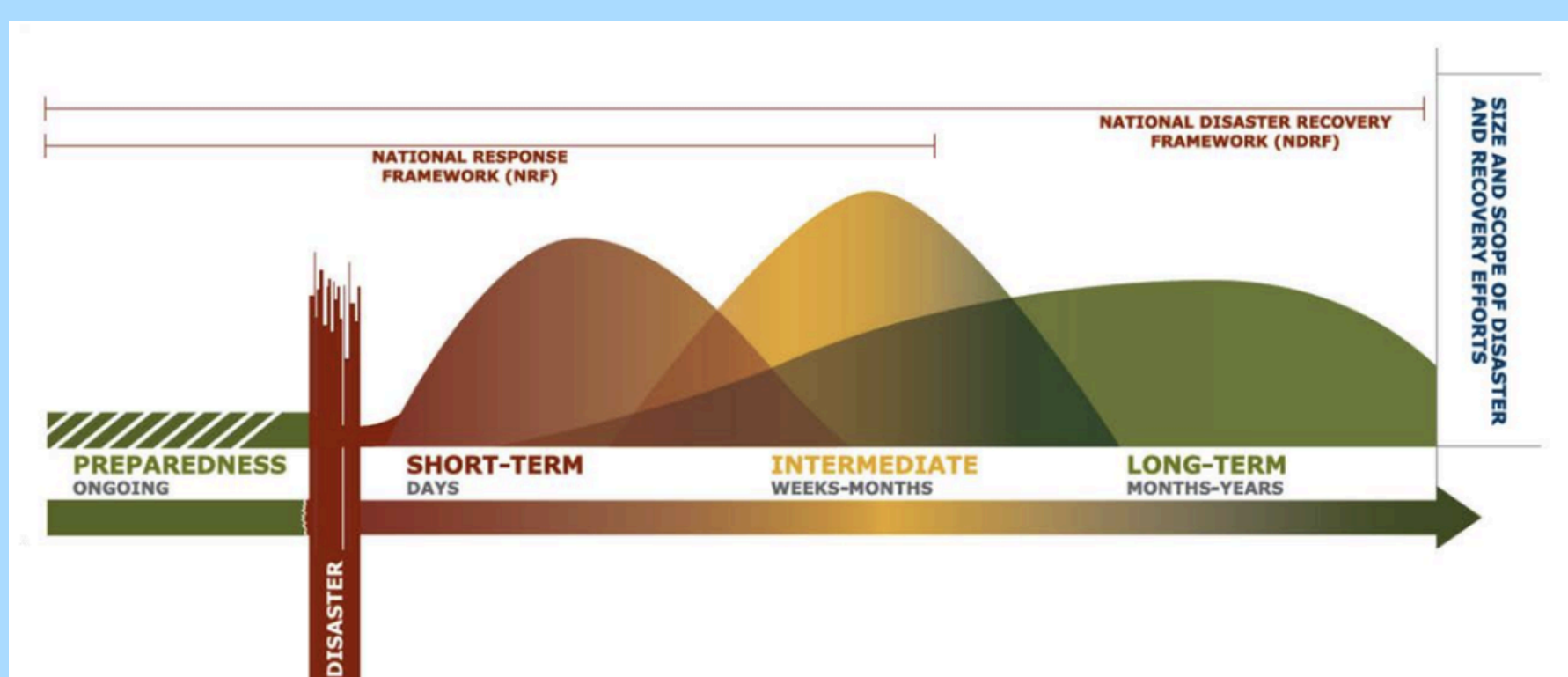

The affordable housing market is defined by high demand and severe supply constraints, with **1-7 MILLION UNITS** needed for low-income and displaced populations.

RENTAL HOMES AFFORDABLE AND AVAILABLE PER 100 EXTREMELY LOW-INCOME RENTER HOUSEHOLDS BY STATE

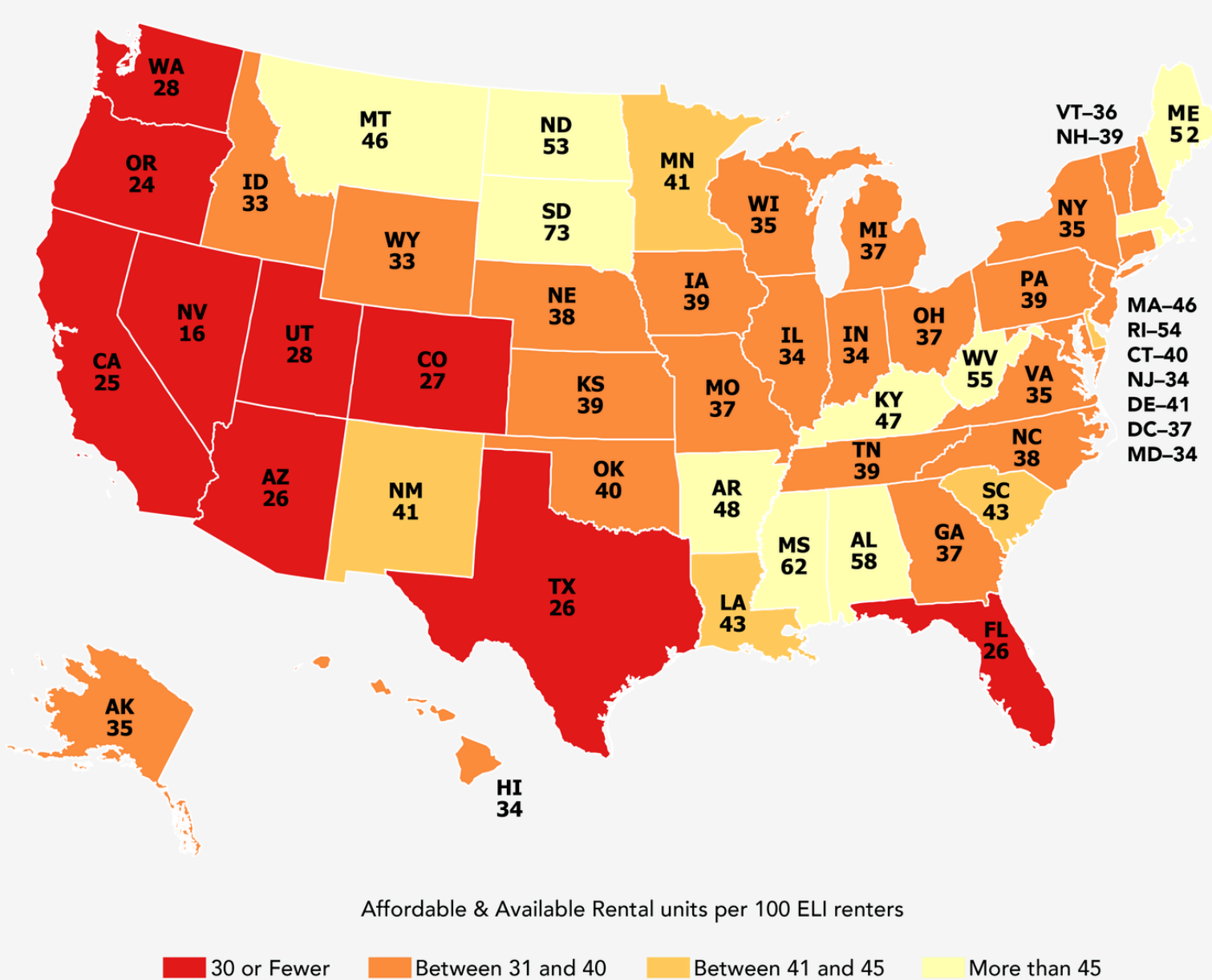

2. CURRENT SOLUTION

Current disaster housing relies on temporary mobile homes and hotel vouchers at **\$110,000-\$129,000 per trailer** and up to **\$42,500 for hotel aid**, with removal required after 18 months. Affordable housing remains subsidy-dependent and slow to scale, with costs of **\$300K-\$500K per unit**.

3. OUR SOLUTION

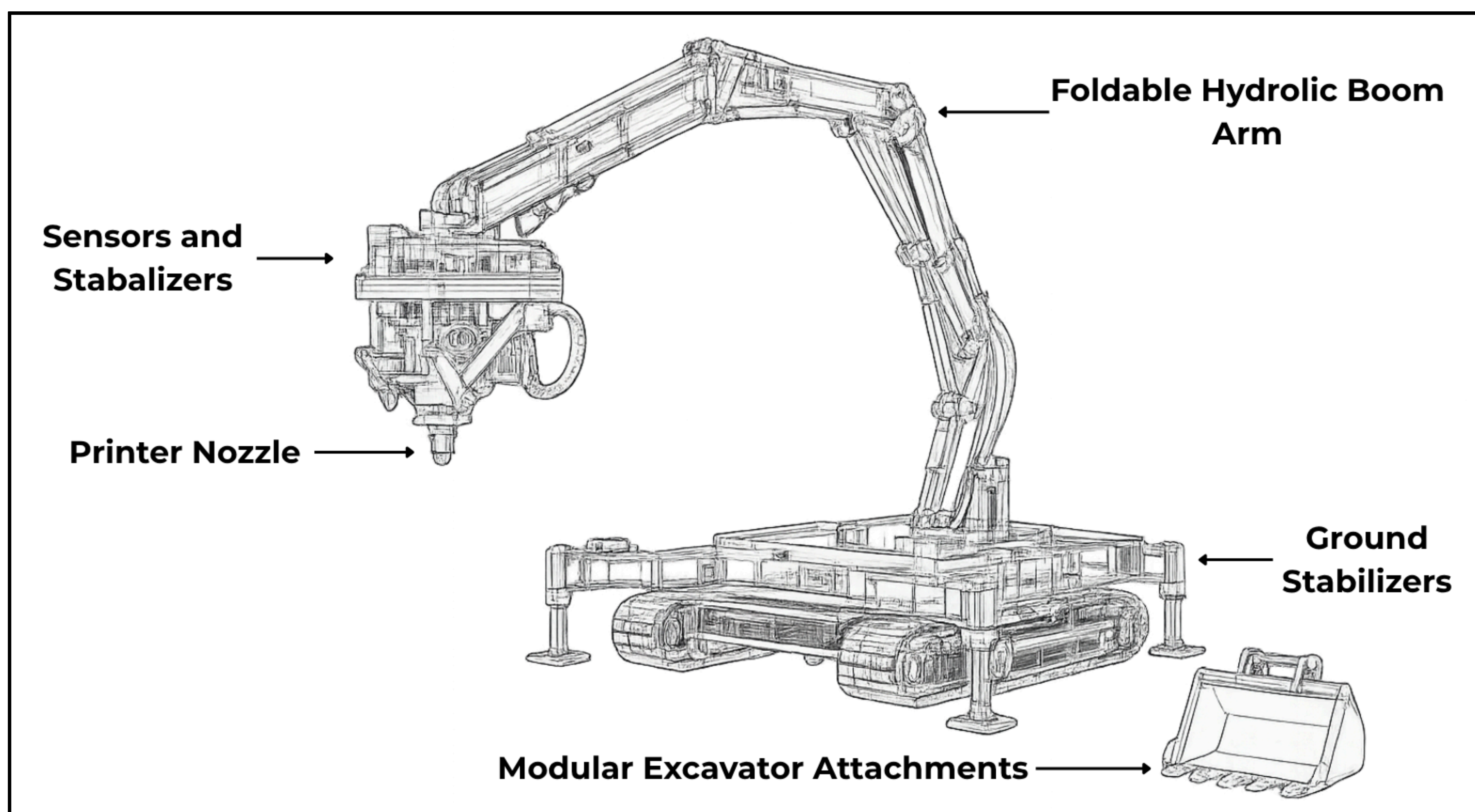

1. Aegex 3D delivers permanent homes using mobile 3D-printing technology.
2. The system uses a rover-based construction platform with robotic arms and stabilizers.
3. It can move across terrain, stabilize on-site, and begin construction with minimal setup.
4. Each home can be built within 24-48 hours for **\$35,000 to \$55,000**
5. The final output is a durable, utility-ready home designed for occupancy.

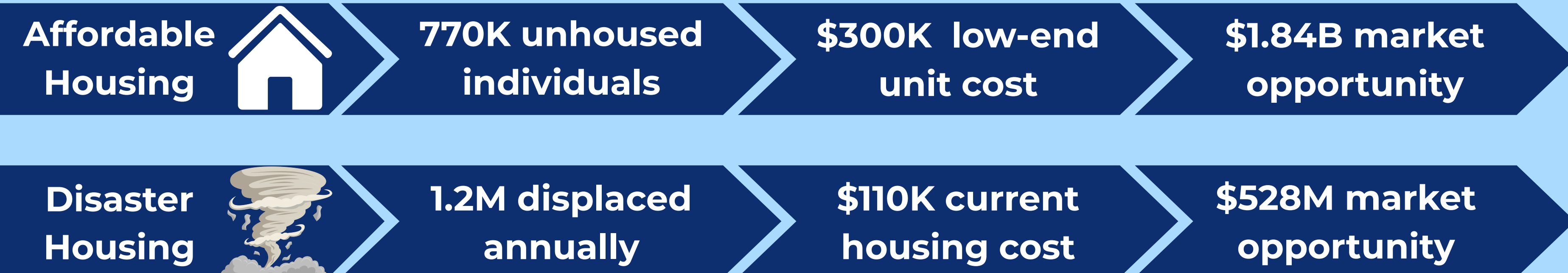

Estimated 1% addressable market across two high-need housing segments

TOTAL MARKET OPPORTUNITY: \$2.3 BILLION

4. PRIMARY CUSTOMERS



FEMA



MEMA



5. FOLLOW UP MARKETS

Military base housing

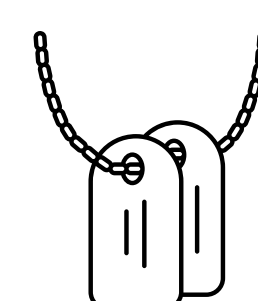

Refugee housing programs



Remote infrastructure

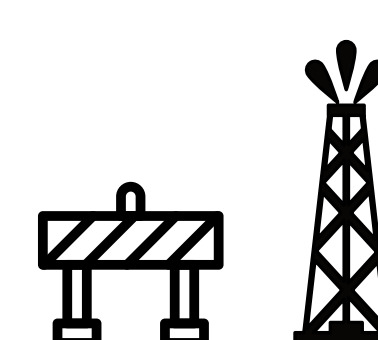

International disaster recovery projects

